

WINNARD

Commercial Vehicle Braking Components

New Design Scania Brake Disc SC1023

Original design

Straight cast ventilation

Braking surface thickness 13.5mm

Vent gap 18mm

Weight 28.5 kg

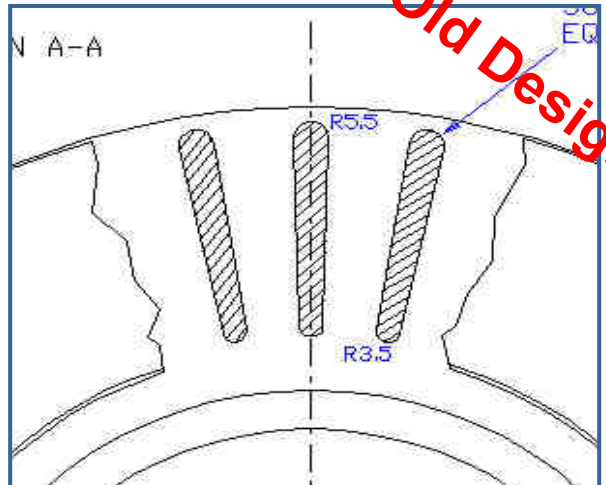

New improved Winnard design

Pillar type ventilation for improved cooling.

Braking surface thickness increased to 17mm

Vent gap reduced to 11mm

Increased weight to 32.2 Kg

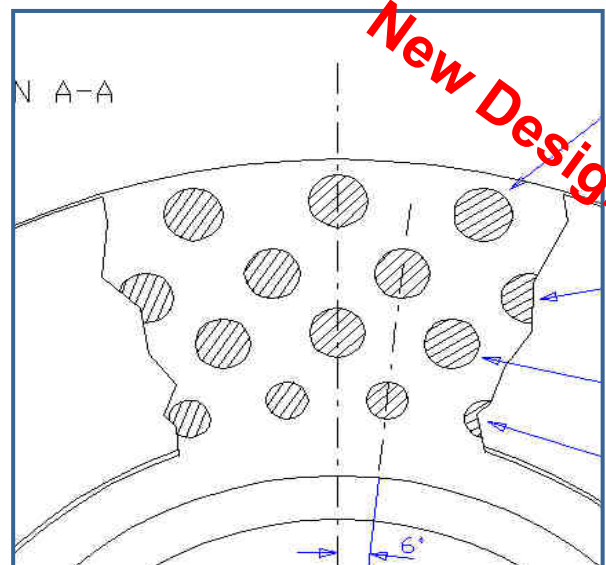

New design improves airflow and improves heat distribution and is therefore less susceptible to cracking.

Winnard

Better by design

Thos. Winnard & Sons Ltd

Mangham Road Rotherham South Yorkshire England S62 6EF
Telephone +44 (0)1709 712000 Export Sales +44 (0)1709 712002 Fax +44 (0)1709 712001
www.winnard.co.uk